

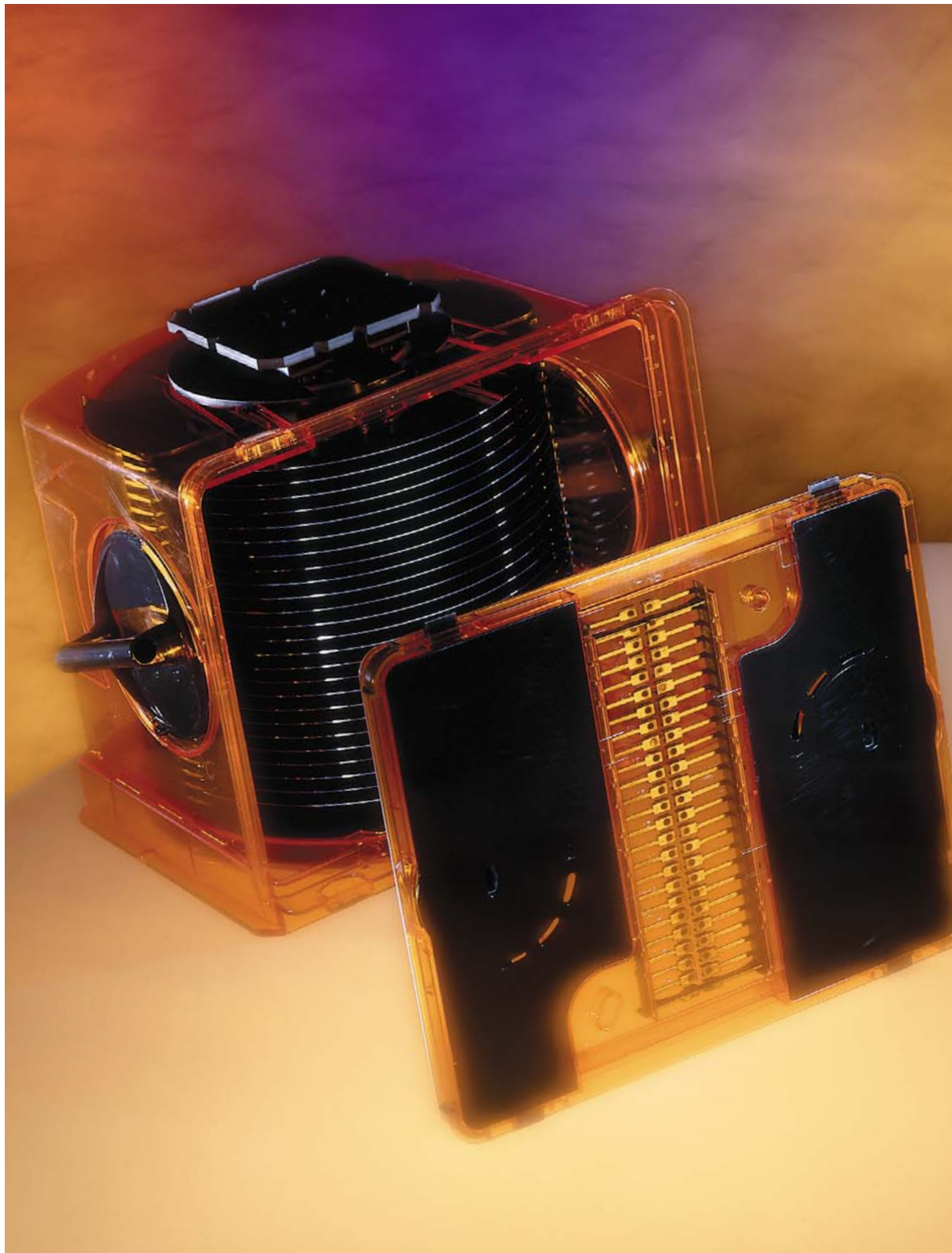

F300 AUTOPOD™ WAFER CARRIER

The F300 AutoPod™ wafer carrier is a 25-capacity front opening unified pod (FOUP) that provides clean and secure wafer transport, optimum automation integration and the highest overall output for your facility



Clean and secure wafer transport, optimum automation integration

Silicon Delivery™ Systems and Services

The F300 is a component of Silicon Delivery™ Systems and Services – Entegris' unique materials integrity management solution to cost-effectively manage silicon from production to consumption. This offering brings together wafer and device handling systems and services into a customized, coordinated package that works for you.

Highest Overall Output for Your Facility

The F300 is engineered to improve the overall productivity of your facility by offering wafer protection and optimum automation interface. Yield and throughput increases are achieved by:

- Maximizing your wafer transfer throughput by precise wafer plane performance
- Maximizing tool and automated materials handling systems uptime and long-term reliability with a dimensionally stable integral cassette
- Door mechanism reliability exceeding 100,000 cycles
- Maximizing water cleaning capability and minimizing dry time for reduced downtime
- Minimizing any contribution to contamination

Clean and Secure Wafer Protection

The F300 is engineered and manufactured to provide maximum protection for your wafers from contamination, electrostatic discharge and UV exposure:

- Ultrapure, UV filtering (to 500 nm) polycarbonate housing material
- Static dissipative STAT-PRO® 3000 carbon fiber filled PEEK™ in areas requiring a path to ground
- Integral, single piece cassette provides reliable wafer plane performance
- Robust wafer retainer ensures repeatable water positioning and minimizes particle generation
- Metal-free assembly prevents metallic contamination

Optimum Automation Performance

The F300 incorporates a variety of features to provide reliable automation interface and interoperability:

- SEMI® standards compliant
- Precise 10 mm wafer spacing with accurate and reliable wafer plane
- 142 mm square top robotic lifting flange
- Lower side conveyor rails
- Kinematic coupling plate
- Configurable A, B, C or D info pads for product segregation
- FIMS interface two-key door



Specifications

- Overall size:
 - Depth: 344 mm (13.5")
 - Width: 430 mm (16.9") handle to handle
 - Height: 332 mm (13.1")
- Wafer Spacing: 10 mm
- Weight without wafers: 4.5 Kg (10 lb)
- Weight with wafers: 7.69 Kg (17 lb)

Material Description

STAT-PRO® 3000

Entegris' STAT-PRO® 3000 material is an advanced, static dissipative blend of polyetheretherketone (PEEK™ polymer) and carbon fiber. Used in the wafer supports and robotic lifting flange, this material offers:

- Static protection
- Low particle generation
- Abrasion resistance
- Dimensional stability
- Temperature limit:
 - Wafer insertion: 300°C

UV polycarbonate material

Entegris' UV polycarbonate material is a blend of polycarbonate and a UV filtration additive. Used in the housing and door, this material offers:

- Low inorganics
- Low particle generation
- Low outgassing
- Dimensional stability
- UV filtering to 500 nm (except clear)
- Proven material of construction

Additional materials

- F300 wafer retainers are manufactured from natural PEEK™ material
- F300 handles are manufactured from polycarbonate

Configuration Options and Accessories

Color Options

- 4 colors for shell and door housing: orange, green, red and clear
- 4 handle colors: black, red, yellow, green

Configuration Options

- 20° and 60° side handles available
- Manual or automation only doors
- AGV rails

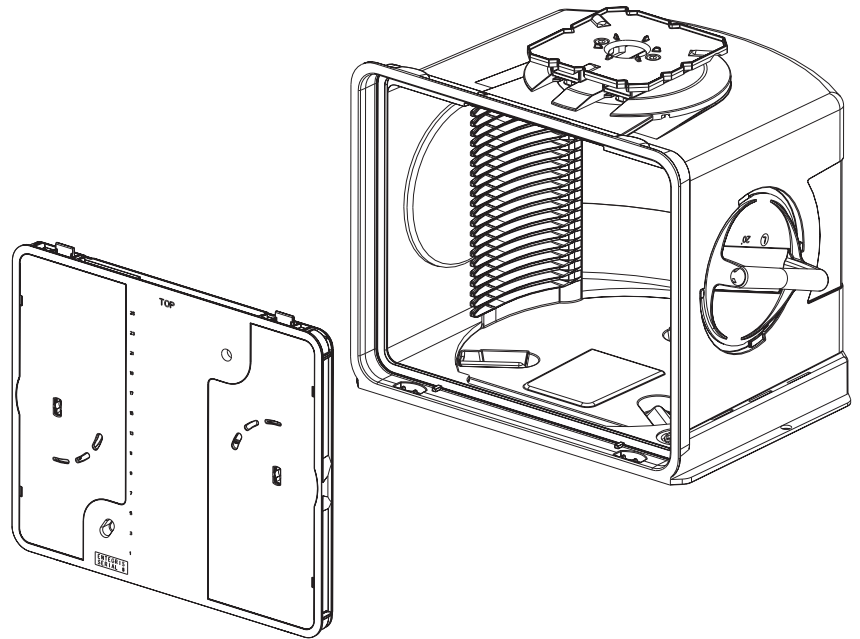

F300 AutoPod™ Wafer Carrier

Segregation Options

- ABCD configurable info pads

Identification Options

- Bar code labels
- Laser marked serial number
- Various RF identification tags with read/write capability are available to accommodate your needs
- 2 size card holder
 - Credit card size: 3.38" × 2.13" (86 × 54 mm)
 - Larger card size: 4" × 2.75" (102 × 70 mm)
- A5 and A6 rear card holder
- RF tag bracket

Accessories

- Door seal
- Filter cartridge assembly
- Removable and nonremovable info pads
- Door keys
- F300 utility tool for removal of configurable info pads, filter cartridge assembly and RF tag holder

Contact your local Entegris representative or Entegris Customer Service at 952-556-4181 for more information on F300 configuration options for your facility.

Ordering Information

Info Pads											
Part Number	Shell Color	A	B	C	D	Handle	Handle Color	Door	ID Options	Card Holder	AGV Rail
F300-1001-11UT09	Orange	C	C	C	C	20°	Black	Auto	2 size card holder	No	No

C = Configurable

Silicon Delivery™ Systems and Services

To optimize wafer and device handling in your facilities, Entegris offers Silicon Delivery™ Systems and Services – our unique materials integrity management solution to cost-effectively manage silicon from production to consumption. Utilizing our systems and services capabilities, Entegris will work with you to develop a customized, coordinated package to address your individual requirements.

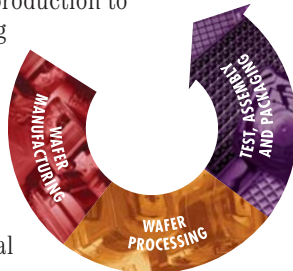

Wafer Handling Systems

- Raw wafer processing and shipping
- Wafer processing
- Finished wafer shipping and handling
- Related product handling
- Handling product cleaning systems

Device Handling Systems

- Finished wafer shipping and handling
- Bare die shipping and handling
- Packaged device shipping and handling
- Handling product cleaning systems

WaferCare™ and DeviceCare™ Services

- Certified reuse and recycle
- Product cleaning
- Logistics management
- On-site and off-site programs

For More Information

Contact your local Entegris representative or your local Entegris Regional Customer Service Center for more information on **wafer shipping** and Silicon Delivery™ Systems and Services for your fab.

For the latest information on the F300, visit Entegris' Web site at www.wafercare.com.

Entegris Regional Customer Service Centers

	Telephone	Fax
North America	952-556-4181	952-556-8022
North America Toll Free	800-394-4083	800-763-5820
Europe	49-7264-9158-0	49-7264-9158-927
Japan	81-3-5769-7800	81-3-5769-7845
Malaysia	604-403-1266	604-403-1262
Korea	82-31-738-1181	82-31-738-1191
Taiwan	886-3-5633598	886-3-5633521
	886-3-5633552	

Terms and Conditions of Sale

All purchases are subject to Entegris' "Terms and Conditions of Sale."

Mykron

Mykron Microelectronics Co., Ltd.

上海资方微电子有限公司

Suite 318, B Office Tower, Poly Plaza

No.14, Dong Zhi Men Street (South), Dong Cheng District

Beijing, 100027, China

Tel. (86)10-6551 0500 Fax (86)10-6551 0501

Entegris™, Silicon Delivery™, WaferCare™ and DeviceCare™ are trademarks of Entegris, Inc.

AutoPod™ and STAT-PRO® are trademarks of Fluoroware, Inc.

PEEK™ is a trademark of Victrex plc.

SEMI® is a registered trademark of Semiconductor Equipment and Materials International (SEMI)

ENTEGRIS, INC.

Corporate Headquarters / 3500 Lyman Boulevard / Chaska, Minnesota 55318 USA

Customer Service Tel. 952-556-4181 / Customer Service Fax 952-556-8022 / www.entegris.com